



GRP Road Plate 1500mm

Specification Sheet

STS210675

18/06/24

safesite[®]
F A C I L I T I E S



GRP Road Plate

The GRP Road Plate is a modular system of composite sections that link together.

At 44kgs this GRP Road Plate is far lighter and easier to handle than a steel plate. No need for expensive specialist lifting equipment, the GRP Road Plate can be installed in minutes with a 2 person lift. The integrated anti-skid surface, which exceeds current road plate standards, provides positive traction, for both vehicle and pedestrian traffic.



Can take up to 44 tonnes



Road plates Lifting Handle

GRP Road Plate Specification

Description	Size (mm)	Weight (kg)
STS210675 - GRP Road Plate	H75 x W1500 x D500	40
STS210695 - GRP End Plate (Blue)	H75 x W1500 x D500	10
STS210880 - GRP Road Plate Lifting Handle	H196 x W925 x D457	3

Key Features

- > Molded anti-skid surface
- > Modular Composite Road Plate System
- > Heavy duty steel drop pins increase lateral stability
- > Tested to a vehicle weight of 44 tonnes over a 700mm trench
- > End sections equipped with anchor holes to accommodate securing to the roadway
- > Heavy duty linking connectors lock the road plates together securely
- > High visibility feature provides traffic calming





Technical Details

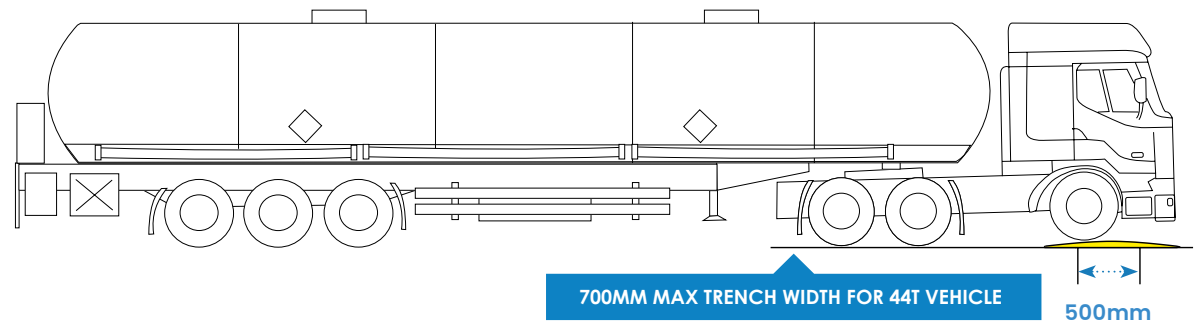
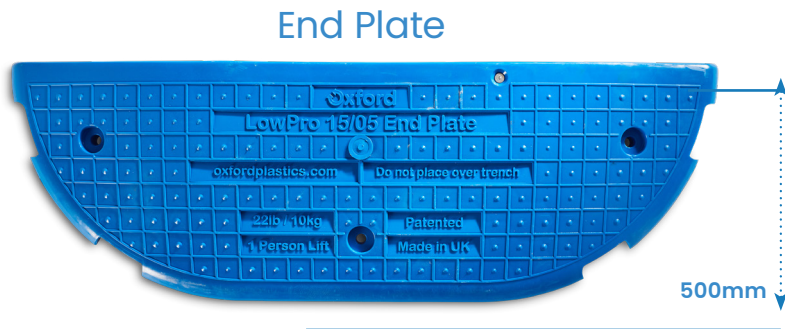
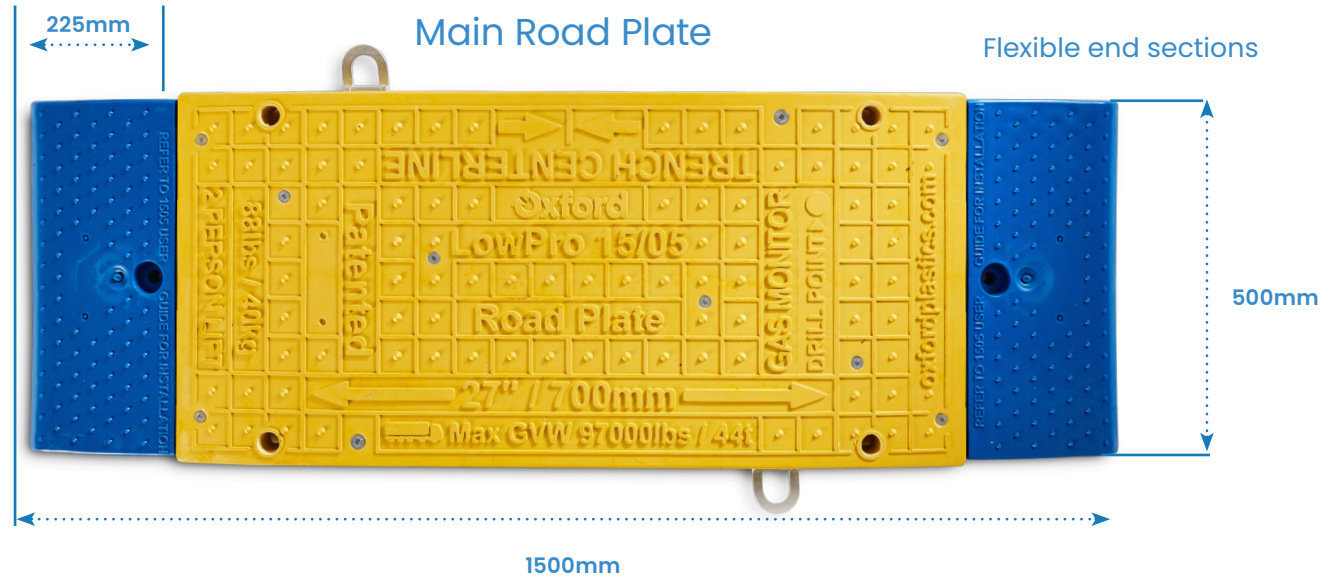



Accessories

1 GRP Road Plate Lifting Handles
Quantity: 2

Size (mm)	Weight (kg)
H925 x W457	5



GRP Lifting Handles - 2 person lift

